



To find the location nearest you
Call 1-888-383-2226
Or visit us on the internet at
www.palfleet.com

PK6501AL Tank Vehicle



Regular Price

~~\$73,715.00~~

Plus applicable taxes

Includes

Ford F550 Chassis

Aluminum Platform Body w/ bulkhead and integrated storage compartments

Palfinger #HP6501 Articulating Crane w/ Full Power Outriggers

Assorted Underbody Storage Boxes

All necessary mounting hardware for safe and legal operation of equipment in a propane tank delivery application

See back of page for detailed specifications

Show Special \$69,785.00 Plus applicable taxes



TRUCK SPECIFICATIONS: 2011 Ford F-550 Chassis 4x4 SD Regular Cab 201" WB DRW XL (F5G)

Engine: 6.8L EFI V-10 Engine

GVWR: 19,500 lb Payload Plus Upgrade Package

Emissions System: 50 State

Interior Color: Steel Viny

XL Value Package: Cruise Control, AM/FM Stereo CD/Clock, Aux Audio Input Jack

Added Options: Stainless steel nerf bars, Stainless steel wheel simulators, Safety video system with rear mounted camera and 7" color monitor, 10 lb. fire extinguisher w/ bracket in crane pedestal compartment, safety road reflector kit, (4) D.O.T. safety placards.

Transmission: 5-Speed Auto w/ PTO provision

Rear Axle: 4.88 Ratio Limited Slip

Wheels: 19.5" Painted Steel, **Tires:** 225/70R19.5G BSW AS

Exterior Color: Oxford White

EQUIPMENT SPECIFICATIONS: PK6501AL Tank Delivery Package

Body: 11' OL x 96" W Aluminum platform body with smooth aluminum floor in center of deck and serrated aluminum floor on outside of deck, vertical storage compartments integrated on both sides at front (48" H x 30" W x 20" D with shelves, 2 underbody wheel chock holders on driver side, welded aluminum bulkhead w/ window, ICC step rear bumper, recessed red LED stop/tail/turn, and clear LED back up lights , 2 rows of 3 (6 total) recessed HD "D" rings centered in floor evenly spaced front to rear

Storage Boxes: Alum underbody toolbox 24"x18"x18" pass side, Alum underbody toolbox 36"x18"x18" pass side behind rear axle, Steel Block Box 36"x20"x24" (with expanded metal bottom) driver side at rear.

Crane: Palfinger Model PK6501 knuckle boom/articulating crane; 42,690 ft/lb rating, 400 degree rotation, three-stage boom with 36' 9" maximum hydraulic reach capability, Lifting cap (4,250 lb @ 10', 2,050 lb @ 20', 1,215 @ 30', 490 lb @ 40') 7,050 max lift capacity, KTL cathodic dip painting process, return oil utilization, load holding valves to prevent crane boom from dropping, maintenance-free extension system, PALTRONIC 50 overload protection system, integrated outriggers and subframe.

All equipment completely installed to industry standards with all necessary mounting kits, hydraulic components, reinforcements, and LED body lights to meet FMVSS regulations.

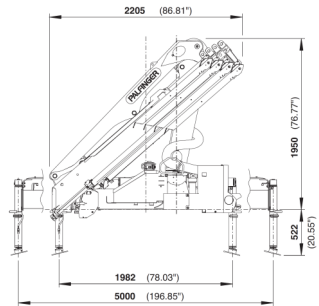
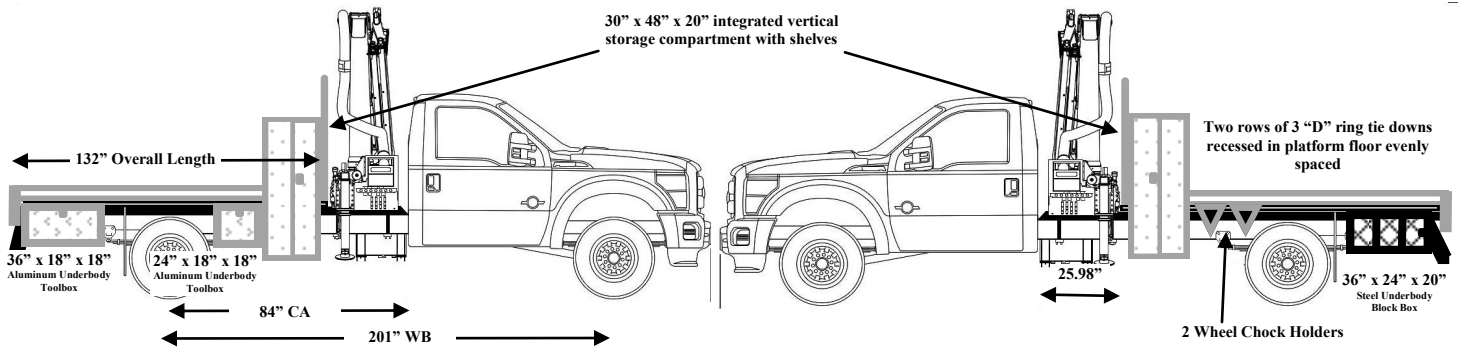

To find the location nearest you
Call 1-888-383-2226
 Or visit us on the internet at
www.palfleet.com